

## Submittal Data

# GA Line ACF - RTCF HR Series

## Gas Fired Absorption Chillers

### Cooling with Heat Recovery

The High Efficiency Chillers ACF HR and RTCF HR series are water chillers, equipped with an air-cooled condenser and designed for outdoor installation. The absorption cooling cycle is based upon a solution of water and

ammonia for the production of chilled water. The chilling system is fed by thermal energy provided by a gas burner, therefore the required electric energy is limited to driving the fan and pump motors.

The evacuation of combustion gases occurs by mixing them with condenser air using the axial fan of the appliance; no flue is needed. The combustion fuel is natural gas or LPG.



#### Version

The ACF and RTCF HR models are standard chillers with a heat recovery system capable of providing from 60,500 to 302,500 BTU/h (it is possible to link up to 5 chillers to obtain RTCF groups) of nominal cooling capacity when operating without the heat recovery system.

With the heat recovery system, it can obtain a cooling capacity from 61,240 to 306,200 BTU/h and, at the same time, provide from 86,400 to 432,000 BTU/h of heating capacity.

Capable of producing hot water up to 180 °F and available in a 4-pipe configuration only.

#### Control and safety devices

The ACF and RTCF HR series units are equipped with the following components and safety devices:

- steel sealed circuit, painted with external epoxy paint;
- steel tube air exchanger with single-row coil and aluminum fins;
- titanium stainless steel tube bundle water heat exchanger, with external insulation;
- variable speed condenser fan, microprocessor controlled;
- S60 Electronic Control Board with integrated microprocessor, LCD display and encoder located inside the electric box; it is programmable and it controls and monitors the operation of the chiller;
- sealed circuit high temperature limit; located on the external wall of the generator; helps prevent overheating of the generator;
- hot water high temperature switch; located on the hot water outlet line; helps prevent overheating of the water circuit;
- flue gas temperature limit switch; located inside the rear portion of the combustion chamber; helps prevent overheating of the generator;
- sealed circuit safety relief valve;
- premixed multigas burner with ignition and flame sensing device managed by an electronic control box;
- differential air pressure switch; located inside the electric box; it helps manage the combustion system by monitoring the air flowing into the air-gas mixing chamber and stopping the burner if the air flow is too low;
- ignition control box; located inside the electric box; it manages the combustion system controlling the

- burner ignition, the gas valve, the air pressure switch, the air blower and the flame sensor;
- dual gas valve;
- chilled water flow sensor; located on the return chilled water line; it monitors the water flow and helps prevent freezing of the evaporator;
- safety by-pass valve; located inside the sealed system; prevents overpressurizing the sealed system;
- antifreeze function for hydronic system; together with the flow switch, this electronic function, programmed into the microprocessor, helps prevent freezing of the evaporator;
- temperature probes; located both on the sealed system and on the water lines; they monitor functional parameters of the unit.

PERFORMANCE RATINGS <sup>(1)</sup>			ACF60	RTCF120	RTCF180	RTCF240	RTCF300
Cooling capacity (no recovery) <sup>(2)</sup>	BTU/h		60,500	121,000	181,500	242,000	302,500
Cooling capacity (with recovery) <sup>(3)</sup>	BTU/h		61,240	122,500	183,700	245,000	306,200
Heating capacity <sup>(3)</sup>	BTU/h		86,400	172,800	259,200	345,600	432,000
Gas input	BTU/h		94,900	189,800	284,700	379,600	474,500
Ambient operating temperature	maximum	°F	120				
	minimum	°F	32				
Chilled water temperature	minimum outlet	°F	37.4				
	maximum inlet	°F	113				
Maximum hot water outlet temperature		°F	176				
Chilled water flow	nominal	GPM	12.2	24.4	36.6	48.8	61.0
	nominal	GPM	9.6	19.2	28.8	38.4	48.0
Recovery system hot water flow	minimum	GPM	0	0	0	0	0
	maximum	GPM	11.0	22.0	33.0	44.0	55.0
Internal pressure drop at nominal chilled water flow		Feet of Head	9.7				
		psi <sub>g</sub>	4.2				
Pressure drop inside recovery system		Feet of Head	4.34				
		psi <sub>g</sub>	3.0				

ELECTRICAL RATINGS <sup>(1)</sup>		
Required voltage, 60 Hz, single phase <sup>(4)</sup>	V	208 - 230
Operating consumption <sup>(5)</sup>	kW	0.75
MCA (Minimum Circuit Ampacity)	A	8.0
MOP (Maximum Overcurrent Protection)	A	10.9

PHYSICAL DATA <sup>(1)</sup>		
Operating weight	pounds	750, 2,040, 3,075, 4,115, 5,127
Chilled / hot water entering and leaving connections	FPT	1", 1 1/2", 2"
Gas inlet connections	FPT	1/2", 1", 1 1/4"
Dimensions	width	inches: 33 1/2, 49 1/2
	length	inches: 48 1/2, 93, 144, 195, 246
	height	inches: 50 3/4, 53 1/4

<sup>(1)</sup> All illustrations and specifications contained herein are based on the latest information available at the time of publication.  
<sup>(2)</sup> Cooling capacity at standard conditions (no recovery): ambient temperature 95 °F. Chilled water outlet temperature 45 °F, chilled water inlet temperature 55 °F.  
<sup>(3)</sup> Cooling capacity at standard conditions (with recovery): ambient temperature 95 °F. Chilled water outlet temperature 45 °F, heat recovery system water temperature - delivery 122 °F - return 104 °F.

<sup>(4)</sup> Units are factory-wired for 208-230 volts operation.  
<sup>(5)</sup> May vary by ± 10% as function of both power supply and electrical motor input tolerance.

**Due to continuous product innovation and development, Robur reserves the right to change product specifications without prior notice.**

**COOLING CAPACITY (BTU/h) - Cooling Only**

External ambient operating temperature	Outlet chilled water temperature			
	37.4 °F	41.0 °F	44.6 °F	48.2 °F
32 °F	59,290	59,895	61,105	62,315
41 °F	59,290	59,895	61,105	62,315
50 °F	59,290	59,895	61,105	62,315
59 °F	59,290	59,895	61,105	62,315
68 °F	59,290	59,895	61,105	62,315
77 °F	58,685	59,895	61,105	62,315
86 °F	54,450	59,290	61,105	62,315
95 °F	40,535	52,635	60,500	61,710
104 °F	--	--	53,240	56,265
113 °F	--	--	40,535	47,190

**COOLING CAPACITY (BTU/h) - Cooling + Recovery**

External ambient operating temperature	Outlet chilled water temperature			
	37.4 °F	41.0 °F	44.6 °F	48.2 °F
32 °F	59,403	60,015	61,240	62,465
41 °F	59,403	60,015	61,240	62,465
50 °F	59,403	60,015	61,240	62,465
59 °F	59,403	60,015	61,240	62,465
68 °F	59,403	60,015	61,240	62,465
77 °F	58,790	60,015	61,240	62,465
86 °F	54,504	59,403	61,240	62,465
95 °F	44,705	55,728	61,240	62,465
104 °F	--	54,504	58,178	58,790
113 °F	--	--	48,992	52,054

**HEATING CAPACITY OF THE HEAT RECOVERY UNIT (BTU/h)**

Heat capacity - Output = 2.2 GPM (BTU/h)							
Recovery system hot water return temperature	External air temperature						
	59 °F	68 °F	77 °F	86 °F	95 °F	104 °F	113 °F
50 °F	92,210	92,893	93,576	93,917	95,283	96,308	97,333
68 °F	72,743	75,134	76,978	78,549	80,188	83,330	85,379
86 °F	52,628	55,667	58,570	61,644	65,162	68,577	72,231
104 °F	35,859	39,275	42,007	46,071	50,954	55,667	61,507
122 °F	21,857	24,248	27,356	31,761	37,567	43,714	50,818
140 °F	9,563	12,226	15,368	18,783	25,033	31,420	40,982
158 °F	--	--	8,196	8,982	13,831	21,003	30,395

Heat capacity - Output = 4.4 GPM (BTU/h)							
Recovery system hot water return temperature	External air temperature						
	59 °F	68 °F	77 °F	86 °F	95 °F	104 °F	113 °F
68 °F	92,210	99,040	102,797	106,895	109,286	--	--
86 °F	71,719	78,208	83,604	85,755	89,546	95,625	102,455
104 °F	47,983	54,643	61,473	65,162	71,719	78,549	85,584
122 °F	27,765	34,083	41,426	45,149	53,004	59,868	65,640
140 °F	10,246	16,051	21,447	25,682	34,152	40,299	46,105
158 °F	--	--	8,538	11,953	19,330	23,906	31,078

Heat capacity - Output = 6.6 GPM (BTU/h)							
Recovery system hot water return temperature	External air temperature						
	59 °F	68 °F	77 °F	86 °F	95 °F	104 °F	113 °F
68 °F	96,991	102,455	109,286	--	--	--	--
86 °F	75,134	81,964	88,795	93,269	100,406	105,871	110,993
104 °F	50,886	60,107	66,596	72,368	80,257	87,429	93,917
122 °F	30,224	38,592	44,295	50,203	56,931	64,137	71,377
140 °F	10,929	17,076	22,779	28,346	34,152	40,982	47,813
158 °F	--	--	10,587	14,344	21,174	23,029	33,469

Heat capacity - Output = 8.8 GPM (BTU/h)							
Recovery system hot water return temperature	External air temperature						
	59 °F	68 °F	77 °F	86 °F	95 °F	104 °F	113 °F
68 °F	97,333	104,709	110,993	--	--	--	--
86 °F	76,158	83,399	91,868	97,333	--	--	--
104 °F	51,228	61,302	72,094	78,549	85,106	92,210	99,040
122 °F	30,258	39,275	47,813	54,643	59,902	66,596	76,158
140 °F	14,022	17,144	24,111	29,678	35,859	42,690	49,520
158 °F	--	--	12,704	17,076	22,882	29,712	35,859

Heat capacity - Output = 11.0 GPM (BTU/h)							
Recovery system hot water return temperature	External air temperature						
	59 °F	68 °F	77 °F	86 °F	95 °F	104 °F	113 °F
68 °F	103,924	--	--	--	--	--	--
86 °F	81,281	88,795	102,455	--	--	--	--
104 °F	57,033	64,888	76,295	82,613	88,795	97,572	102,455
122 °F	36,884	41,255	49,520	58,058	63,454	71,104	79,061
140 °F	17,452	21,345	26,331	31,112	38,113	45,798	55,736
158 °F	--	--	13,285	18,100	23,906	30,737	39,275

**ACF-RTCF HR COOLING ONLY PRESSURE DROP**

**ACF-HR (operation for AIR CONDITIONING ONLY (no recovery))**

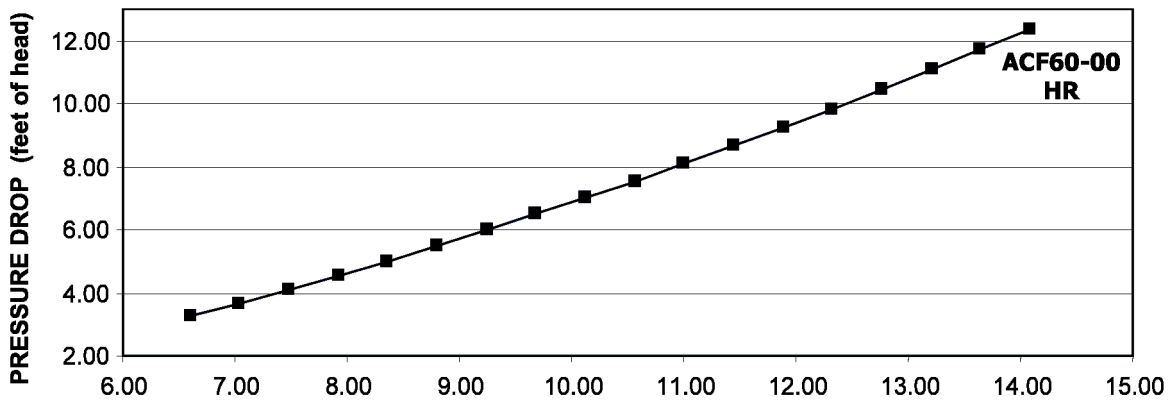

**ACF-RTCF HR HEAT RECOVERY PRESSURE DROP**

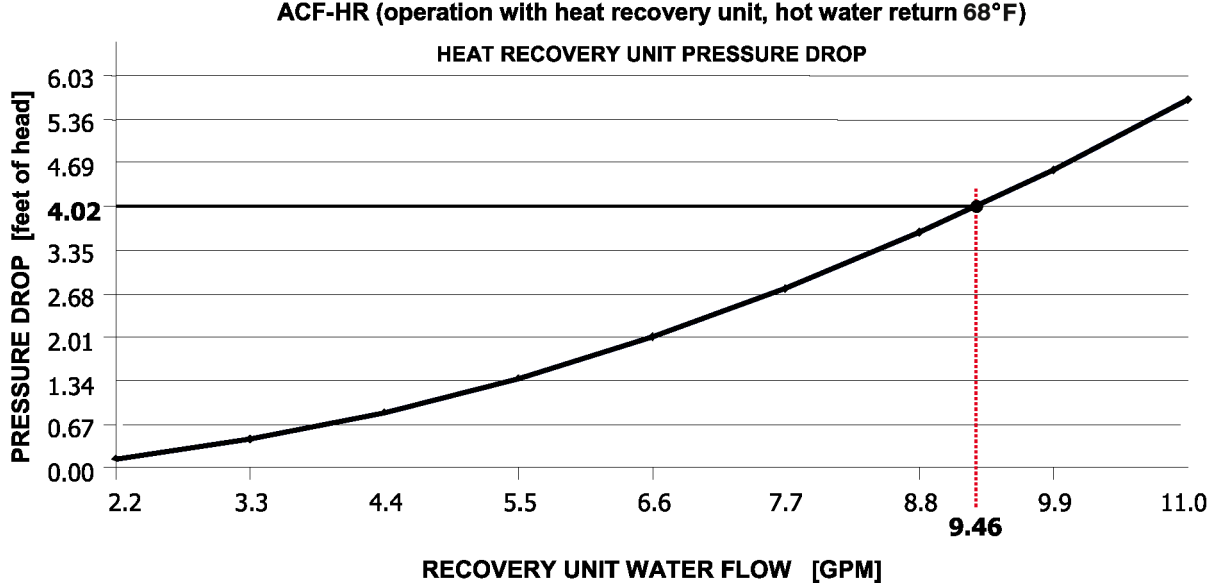

**APPROXIMATE WATER FREEZING POINT TEMPERATURE**

Percentage of monoethylene glycol	10	15	20	25	30	35	40
Water freezing point temperature (°F)	26.6	23.0	17.6	10.4	5.0	-4.0	-13.0
Percentage of increase in pressure drop	--	6	8	10	12	14	16
Loss of efficiency of unit	--	0.5	1	2	2.5	3	4

The numbers provided in this table are approximate and you must refer to the glycol manufacturer's instructions for additional instructions and amount of glycol required based on expected ambient conditions.

**ACF HR DIMENSIONS**

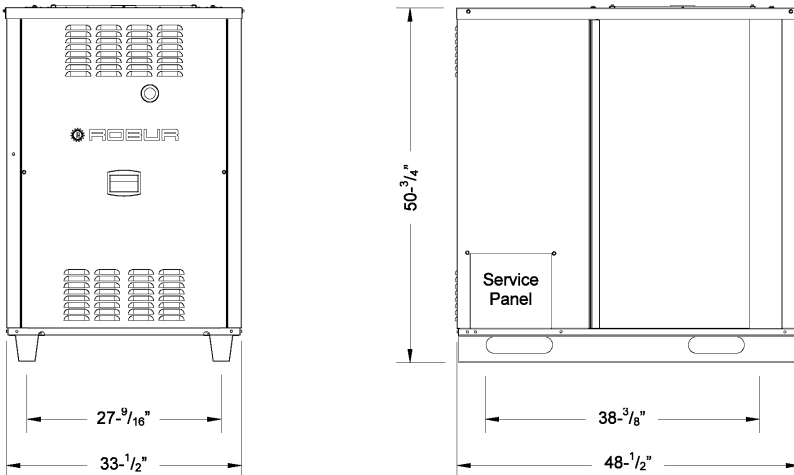

**RTCF HR DIMENSIONS (ALL VERSIONS)**

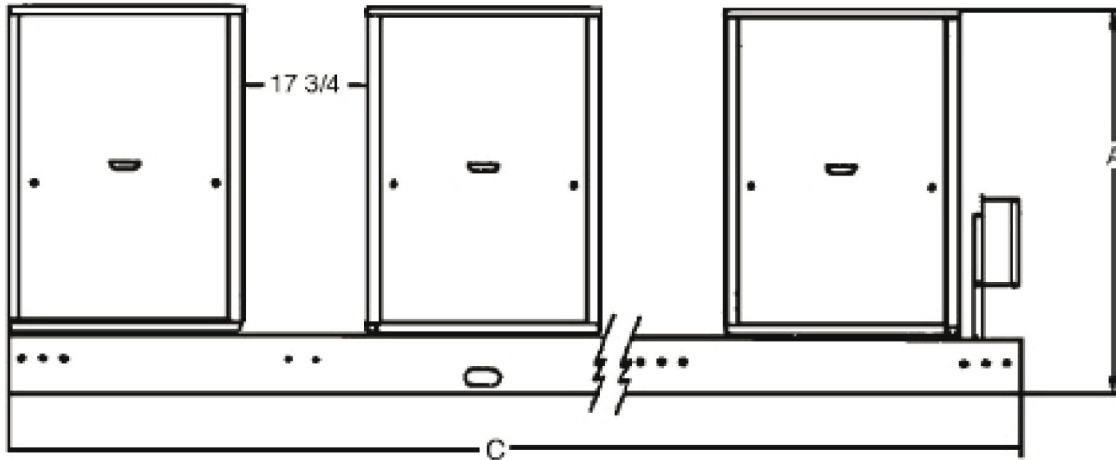

MODEL	A	B depth (not shown)	C	Approximate Weight (lb)	
				shipping	operating
RTCF120	53.25	49.0	93.0	1,870	1,910
RTCF180	53.25	49.0	144.0	2,825	2,880
RTCF240	55.25	49.0	195.0	3,765	3,855
RTCF300	55.25	49.0	246.0	4,690	4,802

**ACF HR SERVICE PLATE DIMENSIONS**

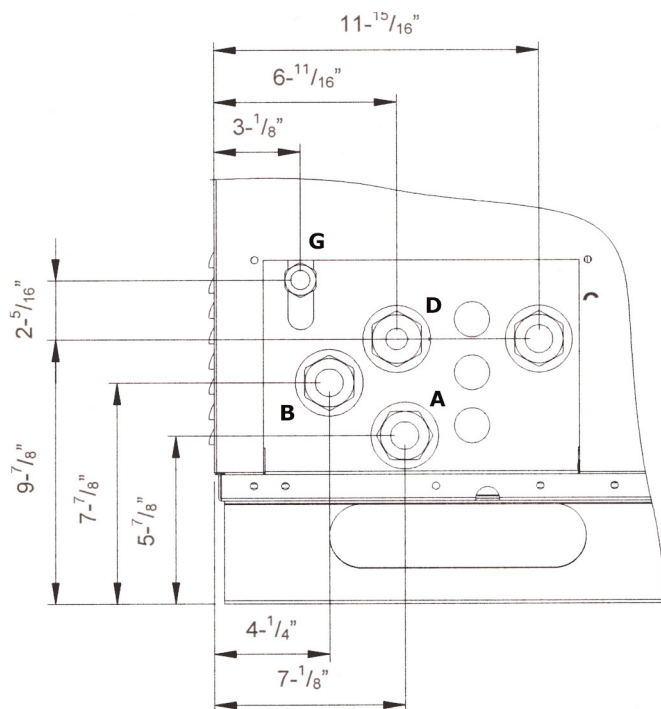

- G** Gas connection  $\varnothing$  1/2" FPT
- Chiller - CHILLED WATER
  - A** Water delivery to appliance  $\varnothing$  1" FPT
  - B** Water return to unit  $\varnothing$  1" FPT
- Recovery unit - HOT WATER
  - C** Water delivery to appliance  $\varnothing$  1" FPT
  - D** Water return to unit  $\varnothing$  1" FPT

**ACF HR HYDRONIC SYSTEM: Typical Installation Arrangement (External Components not included with Robur Unit)**

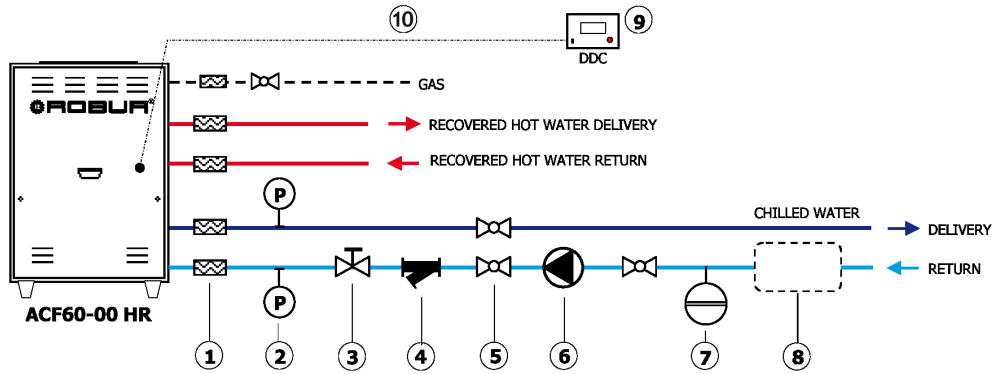

- |                                |  |
|--------------------------------|--|
| 1 Antivibration flexible hoses | 7 Expansion tank                       |
| 2 Pressure gauge               | 8 Water storage                        |
| 3 Flow regulating valve        | 9 DDC (optional from Robur)            |
| 4 Water filter                 | 10 Can Bus cable (optional from Robur) |
| 5 Shut-off valve               |  |
| 6 Circulating water pump       |  |

**RTCF HYDRONIC SYSTEM: Typical Installation Arrangement (External Components not included with Robur Unit)**

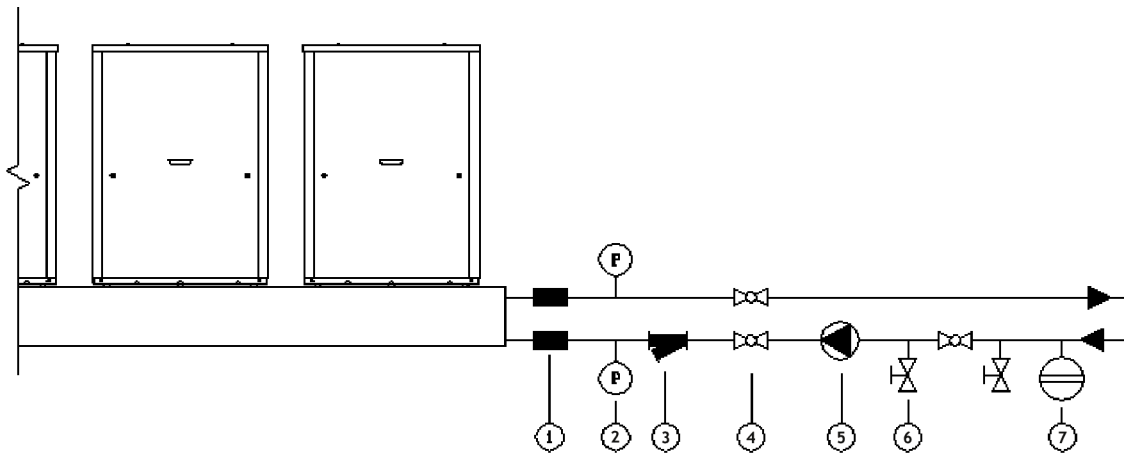

- |                                |                          |
|--------------------------------|--------------------------|
| 1 Antivibration flexible hoses | 5 Circulating water pump |
| 2 Pressure gauge               | 6 Fill/drain valve       |
| 3 Water filter                 | 7 Expansion tank         |
| 4 Shut-off valve               |                          |

**Location**

The ACF and RTCF HR systems must be installed outdoors in an area of free natural air circulation. The installation inside a room or a building is not allowed. There must be a minimum clearance of 4 feet horizontally from electric meters, gas meters, regulators and relief

equipment and in no case located above or below these items unless a 4 foot horizontal distance is maintained. The noise generated by the condenser fan during unit operation is not excessive.

However, avoid locating the unit in an area adjacent to bedrooms or neighboring

buildings. Also, avoid installing the unit in building corners, where air turbulence can take place or the unit noise (reverberation) can be amplified.

**Clearances**

A free space is to be provided around the unit to allow for proper unit operation and for

servicing. The minimum clearance from walls, obstructions and other units must be as follows:  
 - right / left side: 18 inches;  
 - rear side: 24 inches;  
 - front side: 36 inches.

**Observe all local and State codes.**

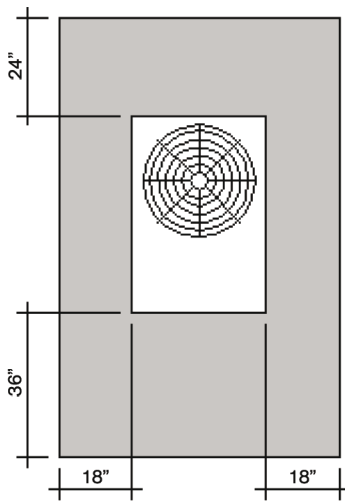

Single unit

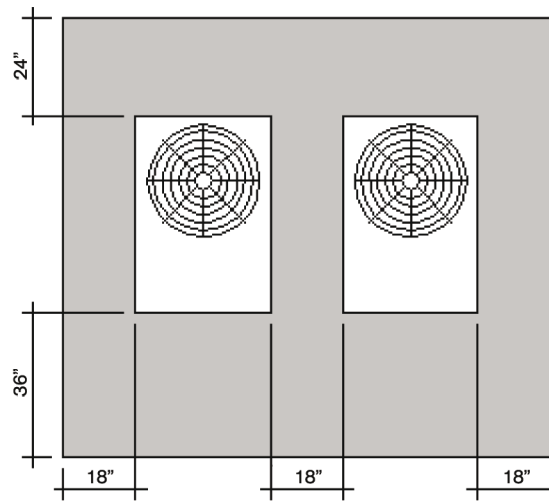

Multiple units