

Submittal Data

GA Line AYF Series Commercial and Specialty Chiller-Heaters

2 or 4 pipe Gas Fired Absorption Chiller-Heater

Cooling and Heating

The High Efficiency AYF60-119 units are 2 module appliances; each AYF is composed of both a water chiller (conditioning module, or chiller module) and a high efficiency boiler (heating module, or hot module). AYF units are designed for outdoor installation, the combustion fuel is natural gas or LPG. The chiller module is equipped

with an air-cooled condenser. The absorption cooling cycle is based upon a solution of water and ammonia for the production of chilled water. The chilling system is fed by thermal energy provided by a gas burner, therefore the required electric energy is limited to driving the fan and pump motors. The evacuation of combustion gases occurs

by mixing them with condenser air using the condenser fan of the appliance; no flue is needed. The heating module evacuates the combustion gases by an appropriate flue, situated in the rear side of the unit. If necessary, a flue extension may be connected to exhaust the discharged gases further away from the unit.



Versions

AYF60-119 units are supplied in 2 configurations: the 2 pipe and the 4 pipe.

AYF60-119/2 is the 2 pipe model: this appliance can alternately work as a chiller or as a boiler. The 2 pipes, inlet and outlet are both used for chilled and hot water, alternatively.

AYF60-119/4 is the 4 pipe model: this appliance can work as a chiller and as a boiler at the same time. 2 pipes are used for the chilled water, and 2 for the hot water. The 2 modules

work independently of each other.

AYF60-119 units (2 and 4 pipes) are available in the standard version and are also supplied in 2 specialty versions.

ST is the standard version. It can produce chilled water down to 37.4 °F and hot water up to 185 °F.

HT - The chilling module of this version is designed to work in climate areas with design temperatures above 104 °F.

TK - The chilling module of this version is designed for

industrial operation or heavy use applications (for example, an industrial process, that could require chilled water up to 24hrs a day).

AYF60-119 units are natural gas or LPG fired and require 208 - 230V 60Hz SINGLE PHASE electrical power.

Control and safety devices

The chiller module includes:

- S60 Electronic Control Board with integrated microprocessor, LCD display and encoder; it is located inside the electric box; it is programmable and it controls and monitors the operation of the chiller;
- sealed circuit high temperature limit; located on the external wall of the generator; prevents overheating of the generator;
- flue gas temperature limit switch; located inside the rear portion of the

combustion chamber; prevents overheating of the generator;

- sealed circuit safety relief valve;
- differential air pressure switch; located inside the electric box; it helps manage the combustion system by monitoring the air flowing into the air-gas mixing chamber and stopping the burner if the air flow is too low;
- ignition control box; located inside the electric box; it manages the combustion system controlling the burner ignition, the gas valve, the air pressure switch, the air blower and the flame sensor;
- dual gas valve;
- chilled water flow sensor; located on the return chilled water line; it monitors the

water flow and helps prevent freezing of the evaporator;

- safety by-pass valve; located inside the sealed system; prevents over pressurizing the sealed system;
- antifreeze function for hydronic system; together with the flow switch, this electronic function, programmed into the microprocessor, helps prevent the freezing of the evaporator;
- temperature probes; located both on the sealed system and on the water lines; they monitor functional parameters of the unit.

The heater module is controlled and monitored by the chiller module's electronic control board through an

electronic card situated on the heater.

The heater module includes:

- flue gas temperature limit switch; located inside the rear portion of the combustion chamber; helps to prevent the overheating of the water heat exchanger;
- high temperature limit switch; located on the outlet water line; helps to prevent the overheating of the water heat exchanger;
- safety relief valve; located on the outlet water line; it controls the water pressure inside the hydronic system;
- differential air pressure switch; located inside the electric box; it helps manage the combustion system controlling the air flowing into the air-gas mixing chamber and stopping the burner if the air

flow is too low;

- ignition control box; located inside the electric box; it manages the combustion system controlling the burner ignition, the gas valve, the air pressure switch, the air blower and the flame sensor;
- dual gas valve;
- differential hot water flow switch; located between the water lines; it monitors the hot water flow and helps prevent the overheating of the water heat exchanger;
- water temperature sensors; they are located on the water lines and they monitor the water temperatures.

PERFORMANCE RATINGS - COOLING ⁽¹⁾			AYF ST	AYF HT	AYF TK
Cooling capacity ⁽²⁾		BTU/h	60,500	58,400	60,500
Gas input		BTU/h	94,900	94,900	94,900
Ambient operating temperature	maximum	°F	120	131	120
	minimum	°F	32	32	10.4
Chilled water temperature	minimum outlet (to hydronic system)	°F	37.4	41	37.4
	maximum inlet (to unit)	°F	113	113	113
Chilled water flow	nominal	GPM	12.2	11.8	12.2

PERFORMANCE RATINGS - HEATING ⁽¹⁾					
Heating capacity	nominal	BTU/h	110,900	110,900	110,900
Gas input	nominal	BTU/h	129,000	129,000	129,000
Ambient operating temperature	maximum	°F	116.6	116.6	116.6
	minimum	°F	-20	-20	-20
Hot water temperature	maximum outlet (to hydronic system)	°F	185	185	185
	maximum inlet (to unit)	°F	167	167	167
Nominal boiler water flow	2 pipe configuration	GPM	12.2	11.8	12.2
	4 pipe configuration	GPM	8.8	8.8	8.8

ELECTRICAL RATINGS ⁽¹⁾					
Required voltage, 60 Hz, single phase ⁽³⁾		V		208-230	
Operating consumption - chiller / heater ⁽⁴⁾		kW	0.75 / 0.076	0.75 / 0.076	0.75 / 0.076
MCA (Minimum Circuit Ampacity)		A		8.0	
MOP (Maximum Overcurrent Protection)		A		10.9	

PHYSICAL DATA ⁽¹⁾					
Pressure drop - chiller	(4 pipe configuration)	Feet of Head / PSig	9.67 / 4.20	9.11 / 3.92	9.67 / 4.20
Pressure drop - heater	(4 pipe configuration)	Feet of Head / PSig	8.30 / 3.60	8.30 / 3.60	8.30 / 3.60
Pressure drop - matched	(2 pipe configuration)	Feet of Head / PSig	17.13 / 7.40	16.25 / 7.10	17.13 / 7.40
Operating weight		pounds	970	1,035	1,035
Dimensions	width	inches		48 7/8	
	length	inches		48 1/2	
	height	inches		50 3/4	

⁽¹⁾ All illustrations and specifications contained herein are based on the latest information available at the time of publication.

⁽²⁾ Cooling capacity at standard conditions of 95 °F ambient temperature. Chilled water outlet temperature 45 °F, chilled water inlet temperature 55 °F.

⁽³⁾ Units are factory-wired for 208-230 volts operation.

⁽⁴⁾ May vary by ± 10% as function of both power supply and electrical motor input tolerance.

Due to continuous product innovation and development, Robur reserves the right to change product specifications without prior notice.

STANDARD VERSION - COOLING CAPACITY (BTU/h)

External ambient operating temperature	Outlet chilled water temperature			
	37.4 °F	41.0 °F	44.6 °F	48.2 °F
32 °F	59,307	59,912	61,123	62,323
41 °F	59,307	59,912	61,123	62,333
50 °F	59,307	59,912	61,123	62,323
59 °F	59,307	59,912	61,123	62,333
68 °F	59,307	59,912	61,123	62,323
77 °F	58,701	59,912	61,123	62,333
86 °F	54,465	59,307	61,123	62,333
95 °F	40,546	52,650	60,517	61,727
104 °F	--	--	53,255	56,281
113 °F	--	--	40,546	47,203
120 °F	--	--	--	39,336

HT VERSION - COOLING CAPACITY (BTU/h)

External ambient operating temperature	Outlet chilled water temperature				
	41.0 °F	44.6 °F	50.0 °F	54.5 °F	57.2 °F
32.0 °F	59,637	59,637	59,637	59,637	60,222
35.6 °F	59,637	59,637	59,637	59,637	60,222
39.2 °F	59,637	59,637	59,637	59,637	60,222
42.8 °F	59,637	59,637	59,637	59,637	60,222
46.4 °F	59,637	59,637	59,637	59,637	60,222
50.0 °F	59,637	59,637	59,637	59,637	60,222
53.6 °F	59,637	59,637	59,637	59,637	60,222
57.2 °F	59,637	59,637	59,637	59,637	60,222
60.8 °F	59,637	59,637	59,637	59,637	60,222
64.4 °F	59,637	59,637	59,637	59,637	60,222
68.0 °F	59,637	59,637	59,637	59,637	60,222
71.6 °F	59,637	59,637	59,637	59,637	60,222
75.2 °F	59,637	59,637	59,637	59,637	60,222
78.8 °F	59,053	59,637	59,637	59,637	60,222
82.4 °F	59,053	59,637	59,637	59,637	60,222
86.0 °F	59,053	59,637	59,637	59,637	60,222
89.6 °F	57,883	59,637	59,637	59,637	60,222
93.2 °F	56,129	59,053	59,053	59,053	59,637
95.0 °F	54,960	58,368	58,468	59,053	59,637
96.8 °F	53,791	57,883	58,468	58,468	59,637
100.4 °F	50,867	56,714	57,883	57,883	59,053
104.0 °F	47,944	54,375	56,714	57,299	58,468
107.6 °F	--	51,452	54,960	56,714	57,883
111.2 °F	--	47,944	53,206	55,545	56,714
114.8 °F	--	--	50,282	53,791	55,545
118.4 °F	--	--	46,774	50,867	53,206
131.0 °F	--	--	--	47,359	50,282

TK VERSION - COOLING CAPACITY (BTU/h)

External ambient operating temperature	Outlet chilled water temperature			
	37.4 °F	41.0 °F	44.6 °F	48.2 °F
10.4 °F	71,410	71,410	72,015	72,620
17.6 °F	70,805	70,805	71,410	72,015
24.8 °F	70,200	70,200	70,200	71,410
32.0 °F	69,595	69,595	69,595	70,200
39.2 °F	68,989	68,989	68,989	69,595
46.4 °F	67,779	68,384	68,384	68,989
53.6 °F	67,779	67,779	67,779	68,384
60.8 °F	67,174	67,174	67,779	67,779
68.0 °F	65,964	65,964	67,174	67,174
75.2 °F	64,148	64,148	66,569	66,569
82.4 °F	59,307	61,727	65,358	65,358
89.6 °F	51,439	57,491	62,938	64,148
95.0 °F	41,757	52,650	60,517	62,333
100.4 °F	--	--	56,886	59,912
107.6 °F	--	--	50,229	55,070
113.0 °F	--	--	--	49,624
120.0 °F	--	--	--	42,057

PRESSURE DROP - CHILLER SIDE - 4 PIPE VERSIONS

Standard, HT, TK versions

Pressure drop (ft _{w.c.})																			
3.25	3.67	4.11	4.56	5.02	5.50	5.99	6.50	7.02	7.56	8.11	8.67	9.11 ¹	9.25	9.67 ²	9.85	10.46	11.08	11.72	12.38
6.60	7.04	7.48	7.93	8.37	8.81	9.25	9.69	10.13	10.57	11.01	11.45	11.78	11.89	12.20	12.33	12.77	13.21	13.65	14.09
Water flow (GPM)																			

1 HT version nominal values
2 ST, TK versions nominal values

PRESSURE DROP - HEATER SIDE - 4 PIPE VERSIONS

Standard, HT, TK versions

Pressure drop (ft _{w.c.})																							
0.65	1.42	2.18	2.95	3.71	4.48	5.24	6.00	6.77	7.53	8.30 ¹	9.06	9.83	10.59	11.36	12.12	12.89	13.65	14.42	15.18	15.95	16.71	17.48	18.24
4.40	4.84	5.28	5.72	6.16	6.60	7.04	7.48	7.93	8.37	8.81	9.25	9.69	10.13	10.57	11.01	11.45	11.89	12.33	12.77	13.21	13.65	14.09	14.53
Water flow (GPM)																							

1 nominal values

PRESSURE DROP - 2 PIPE VERSIONS

In 2 pipe type AYF60-119 units the correct pressure drop is the one of the heater module of the unit.

Standard, HT, TK versions (max = heater side)

Pressure drop (ft _{w.c.})																									
0.74	1.67	2.60	3.52	4.45	5.37	6.30	7.22	8.15	9.08	10.00	10.93	11.85	12.78	13.70	14.63	15.56	16.25 ¹	16.48	17.13 ²	17.41	18.33	19.26	20.18	21.11	22.04
4.40	4.84	5.28	5.72	6.16	6.60	7.04	7.48	7.93	8.37	8.81	9.25	9.69	10.13	10.57	11.01	11.45	11.78	11.89	12.20	12.33	12.77	13.21	13.65	14.09	14.53
Water flow (GPM)																									

1 HT version nominal values
2 ST, TK versions nominal values

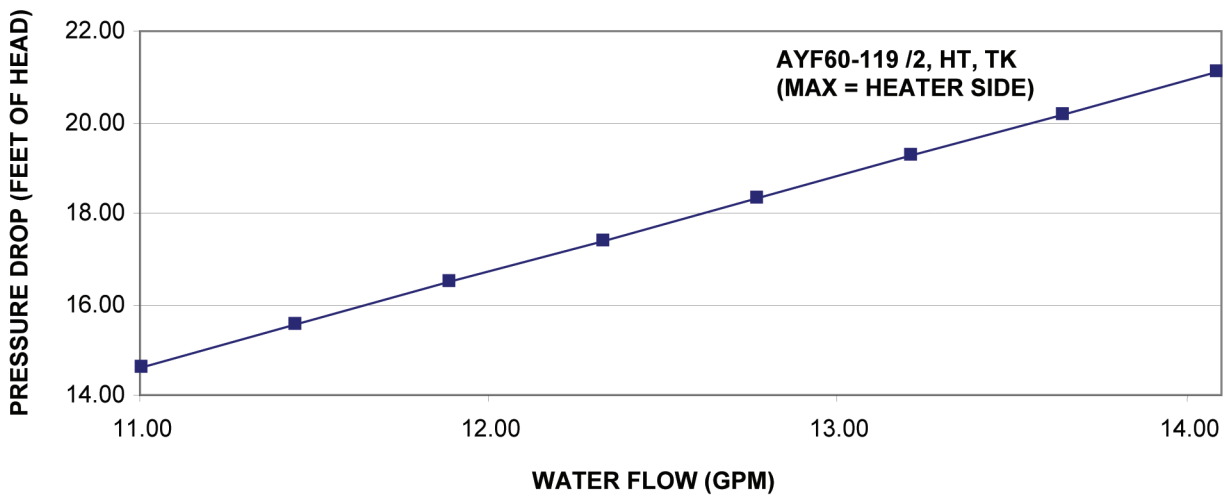
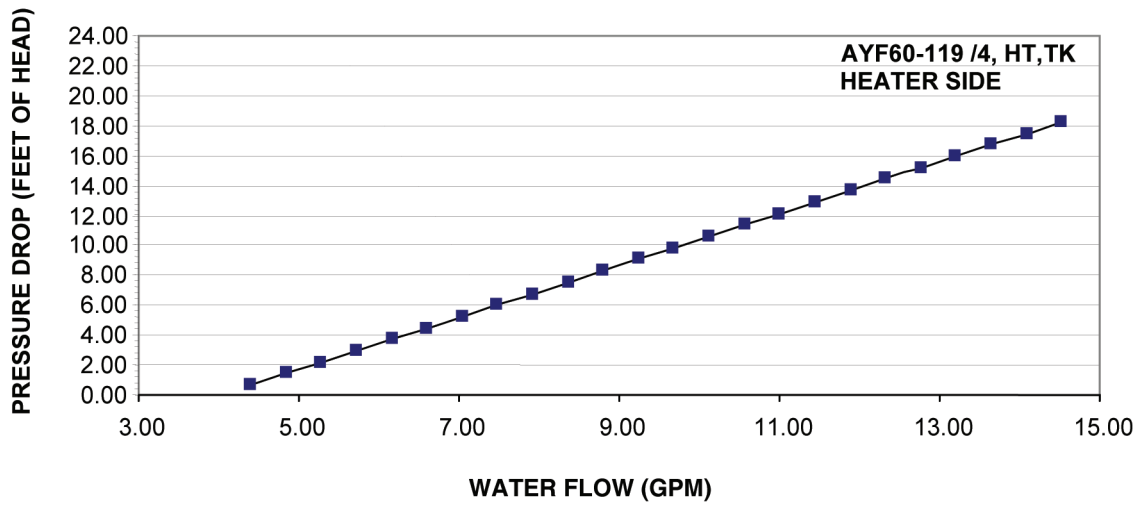
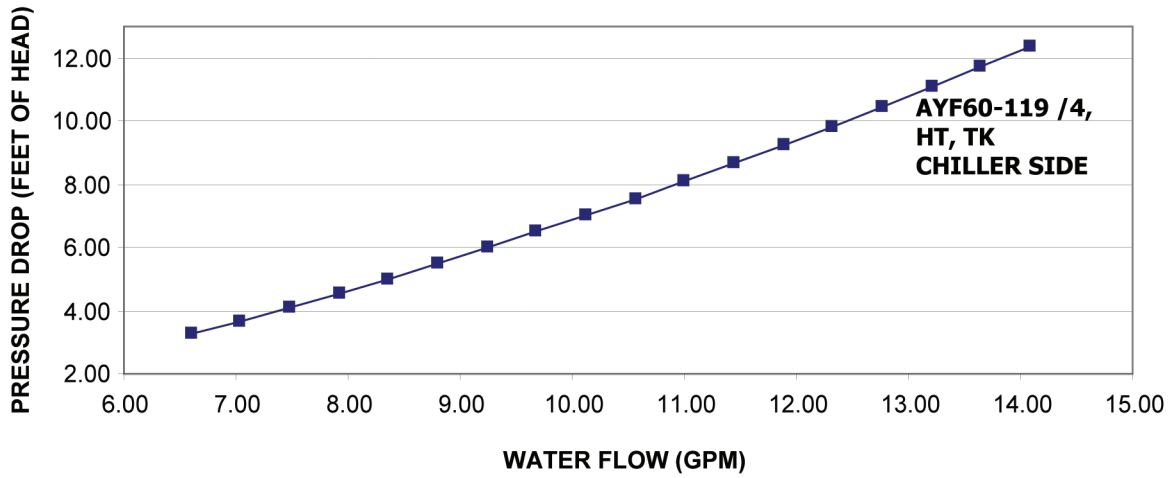

APPROXIMATE WATER FREEZING POINT TEMPERATURE

Percentage of monoethylene glycol	10	15	20	25	30	35	40
Water freezing point temperature (°F)	26.6	23.0	17.6	10.4	5.0	-4.0	-13.0
Percentage of increase in pressure drops	-	6	8	10	12	14	16
Loss of efficiency of unit (%)	-	0.5	1	2	2.5	3	4

The numbers provided in this table are approximate and you must refer to the glycol manufacturer's instructions for additional instructions and amount of glycol required based on expected ambient conditions.

AYF DIMENSIONS (all versions)

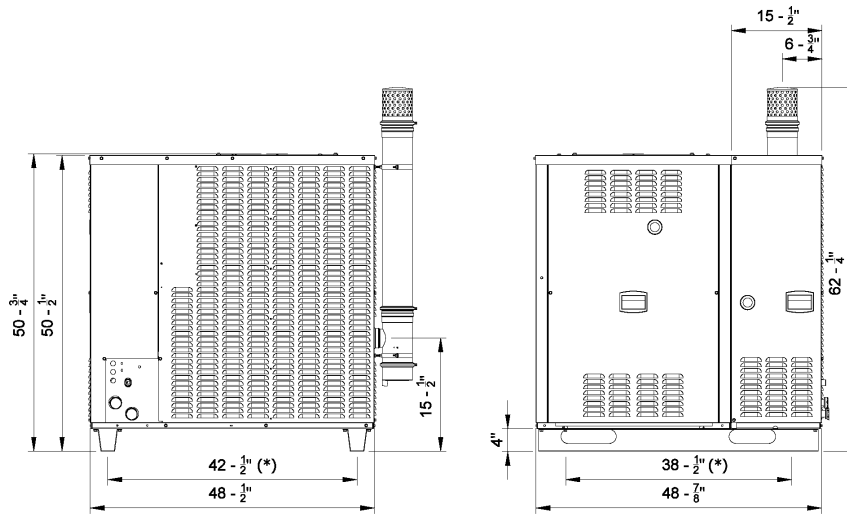

AYF SERVICE PLATE DIMENSIONS (all versions)

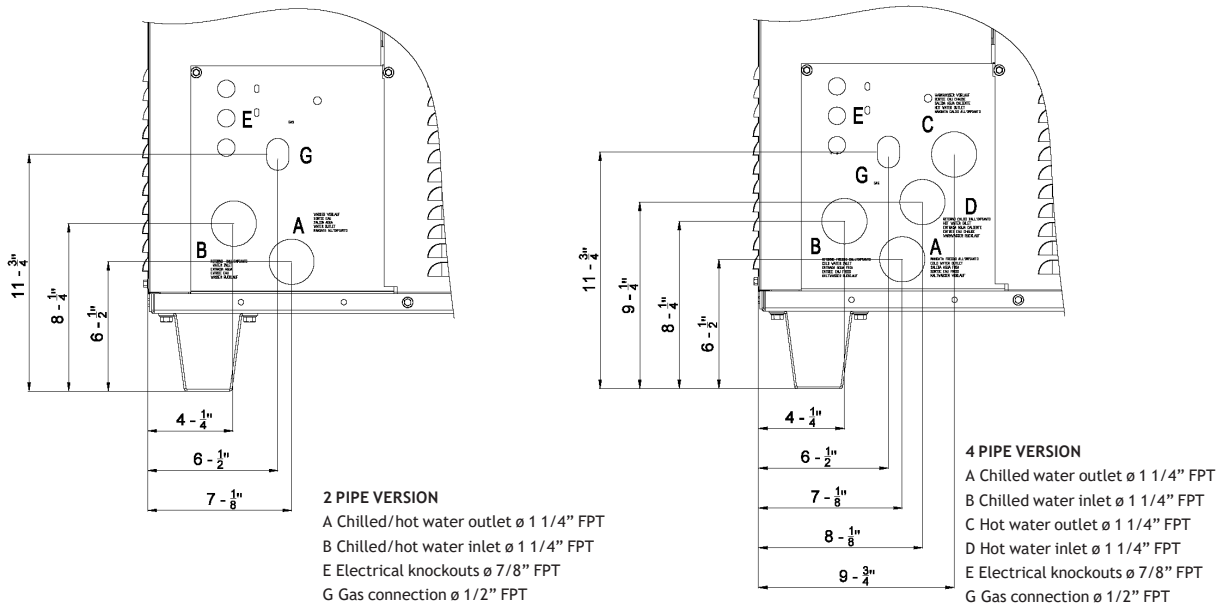

2 PIPE AYF HYDRONIC SYSTEM: Typical Installation Arrangement (External Components not included with Robur Unit)

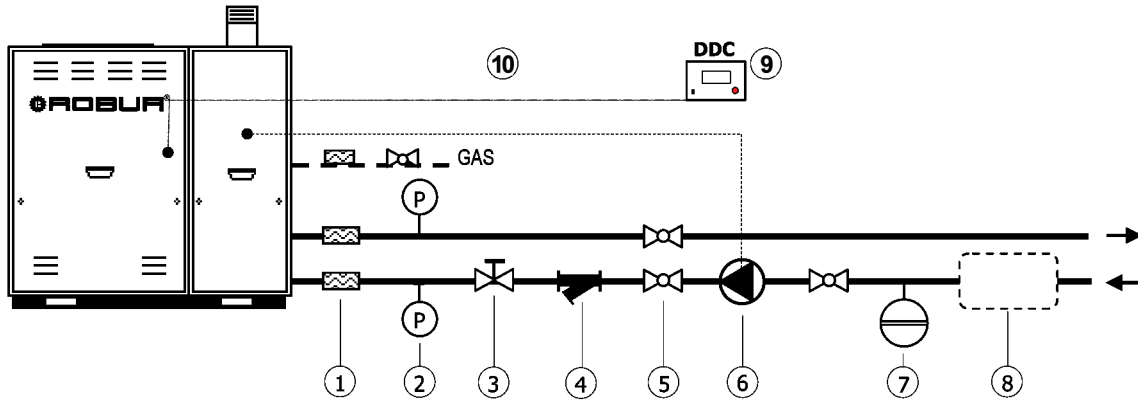

- | | |
|--------------------------------|--|
| 1 Antivibration flexible hoses | 6 Circulating water pump |
| 2 Pressure gauge | 7 Expansion tank |
| 3 Flow regulating valve | 8 Water storage |
| 4 Water filter | 9 DDC (optional from Robur) |
| 5 Shut-off valve | 10 Can Bus cable (optional from Robur) |

4 PIPE AYF HYDRONIC SYSTEM: Typical Installation Arrangement (External Components not included with Robur Unit)

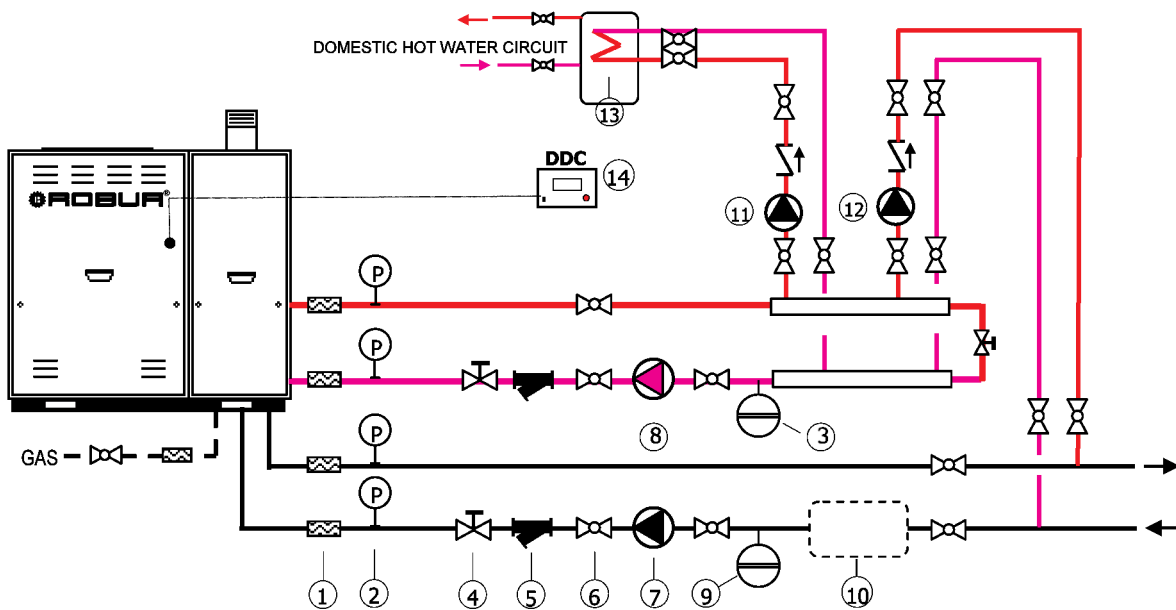

- | | | | |
|--------------------------------|--|--------------------------------------|------------------------------|
| 1 Antivibration flexible hoses | 5 Water filter | 8 Primary circulating hot water pump | 12 Heating pump |
| 2 Pressure gauge | 6 Shut-off valve | 9 Expansion tank | 13 Domestic hot water boiler |
| 3 Hot water expansion tank | 7 Primary circulating chilled water pump | 10 Water storage | 14 DDC (optional from Robur) |
| 4 Flow regulating valve | | 11 Domestic water circulating pump | |

Location

The AYF60-119 must be installed outdoors in an area of free natural air circulation. The installation inside a room or a building is not allowed. There must be a minimum clearance of 4 feet horizontally from electric meters, gas meters, regulators and relief equipment and in no case located above or below these items unless a 4 foot horizontal distance is maintained. The noise generated by the condenser fan during unit operation is not excessive. However, avoid locating the unit in an area adjacent to bedrooms or neighboring buildings. Also, avoid installing the unit in building corners, where air turbulence can take place or

the unit noise (reverberation) can be amplified.

Clearances

A free space is to be provided around the unit to allow for proper unit operation and for servicing. The minimum clearance from walls, obstructions and other units must be as follows:
 - right / left side: 18 inches;
 - rear side: 24 inches;
 - front side: 36 inches.
 There must not be any obstructions or structural overhangs (roof edges, balconies) over the top of the unit. The re-circulation of the air discharged from the condenser results in poor unit performance.

When the unit is installed in close proximity to buildings,

keep the unit away from the roof edge drip line. In no case should the unit be placed within 6 feet of any external air intakes of the building. For installations on balconies or roofs, the unit should not be located within 8 feet from chimney flues, outlets and other such vents. It is important that the unit is located so that hot or contaminated air is not drawn into the air intakes of the unit.

Ground installation

Ground level units should be supported on a level concrete pad with a minimum thickness of 4" and slightly larger than the unit base. Local soil conditions will actually dictate the slab thickness

required to prevent shifting. Do not allow the concrete slab to touch the foundation of a structure. Unit operational noises can be transmitted inside the structure if they are connected.

Leveling

The unit should be level both front to back and side to side. Place a level on the top of the unit to check for level. If the unit is not level, metal shims are recommended for use under proper corners to obtain level. If the shim(s) thickness exceeds 1/2", support shims should be inserted under the center of the unit.

Observe all local and State codes.

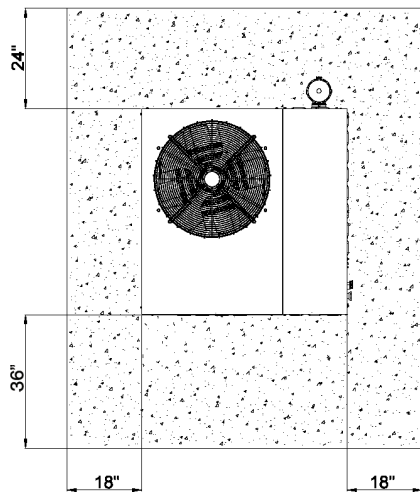

Single unit

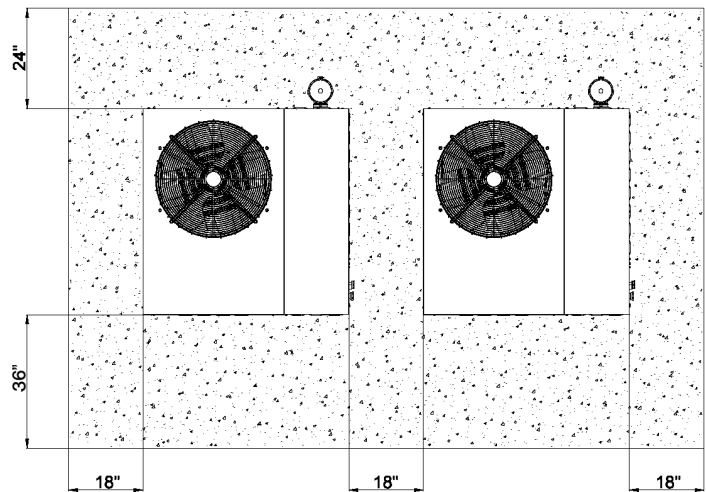

Multiple units